

**Innovative
Designs
Sustainable
Solutions**



 **SAMTAS**

About Us

Custom Metal Solutions Shaped by Expertise

Samtaş started its operations in 1992 with the production of cold sheet cutting, forming, and mold manufacturing, establishing its expertise, particularly in sheet metal production for the automotive industry. With a quality-focused approach, the company continuously improved its capabilities and, in 2007, combined its 15 years of experience in the seating industry with mold manufacturing, transitioning into a strong partnership structure. This step enabled Samtaş to offer innovative solutions in metal spare parts production, securing a significant position in the industry.

Today, exporting 85% of its production to Europe, Samtaş specializes in manufacturing metal spare parts for entertainment and social venues, maintaining a customer-oriented production approach. The company produces high-quality components for casinos, bars, cafes, restaurants, cinema, conference hall and stadiums, working closely with customers to develop joint designs and serve as a reliable solution partner. Operating in a 3,000 m² closed production facility in Bursa, Samtaş continues to stand out in the industry with its innovative design support and high-quality manufacturing.



Our Policies

We Move Forward with Confidence, Guided by Our Values.

Samtaş creates a difference in the industry by providing high-quality production and innovative solutions with a customer-focused approach and ethical working principles. It operates with respect for continuous development, teamwork, and the environment.



Our Vision

To be a leading company preferred in Türkiye and globally, through the metal spare part production and services we provide in the retail sector.



Our Mission

With our team, which adopts a customer-focused approach and is committed to our company values, we aim to provide high-quality, reliable, and solution-oriented services that exceed expectations.



Our Values

We foster an ethical and reliable work environment, prioritizing respect for nature, the environment, and humanity. Success, development, teamwork, and honest communication are key to us.

Comprehensive Manufacturing Solutions

Samtaş, as a company specialized in high-quality production and engineering services, offers a wide range of expertise in key areas such as CNC Tube Bending, Sheet Metal Forming, Welding, Molding, and Polishing.

CNC Tube Bending

Sheet Metal Forming

Welding

Molding

Polishing



Furniture Legs

SMT-101

Specification Metal Leg

Color Chart

SMT-102

Specification Metal Leg

Color Chart

SMT-103

Specification Metal Leg

Color Chart

SMT-104

Specification Metal Leg

Color Chart

Furniture Legs

SMT-105

Specification Metal Leg

Color Chart

SMT-106

Specification Metal Leg

Color Chart

SMT-202

Specification Metal Leg

Color Chart

SMT-205

Specification Metal Leg

Color Chart

Diameter: 620mm

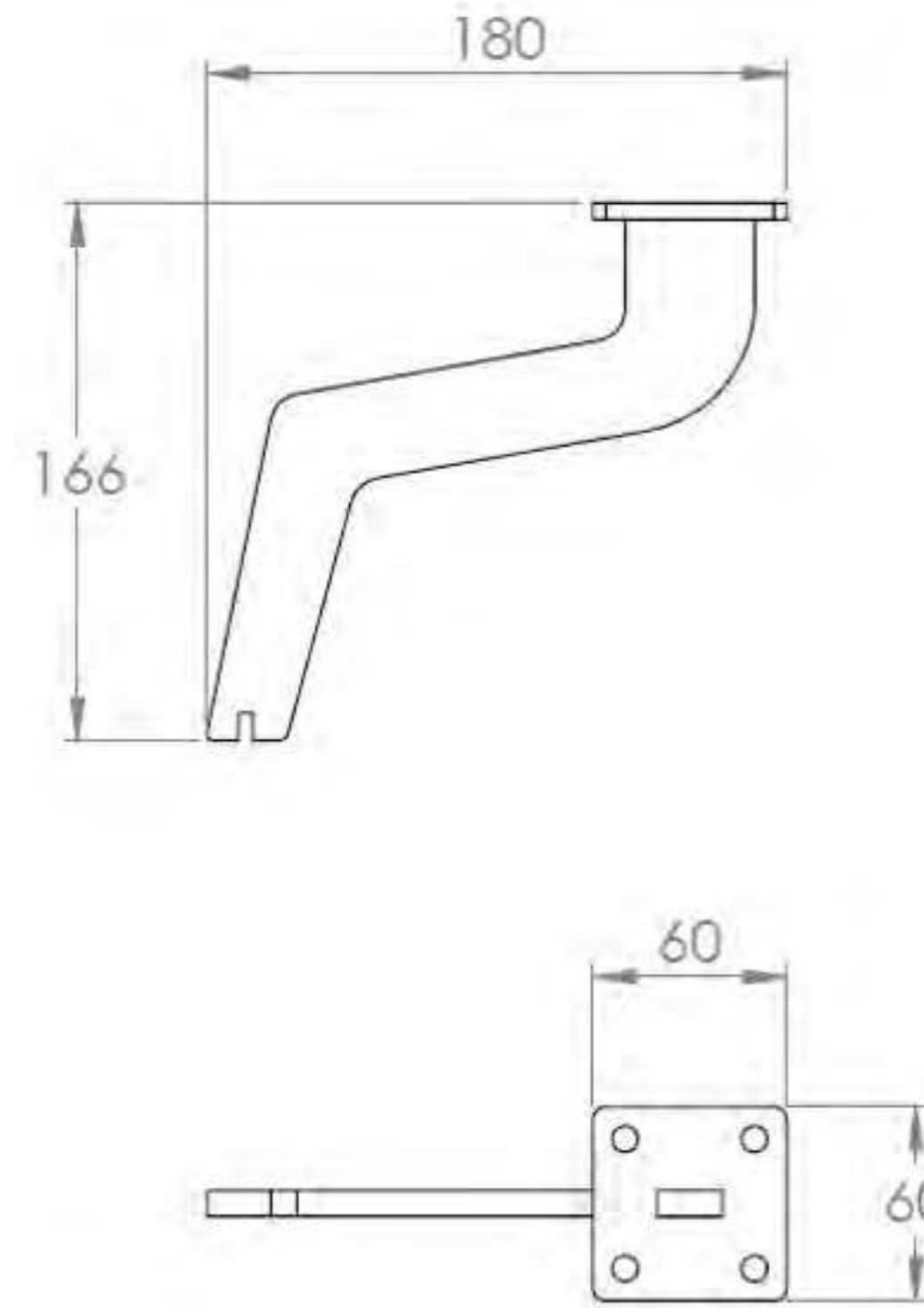

Furniture Legs

SMT-301

Specification Metal Leg

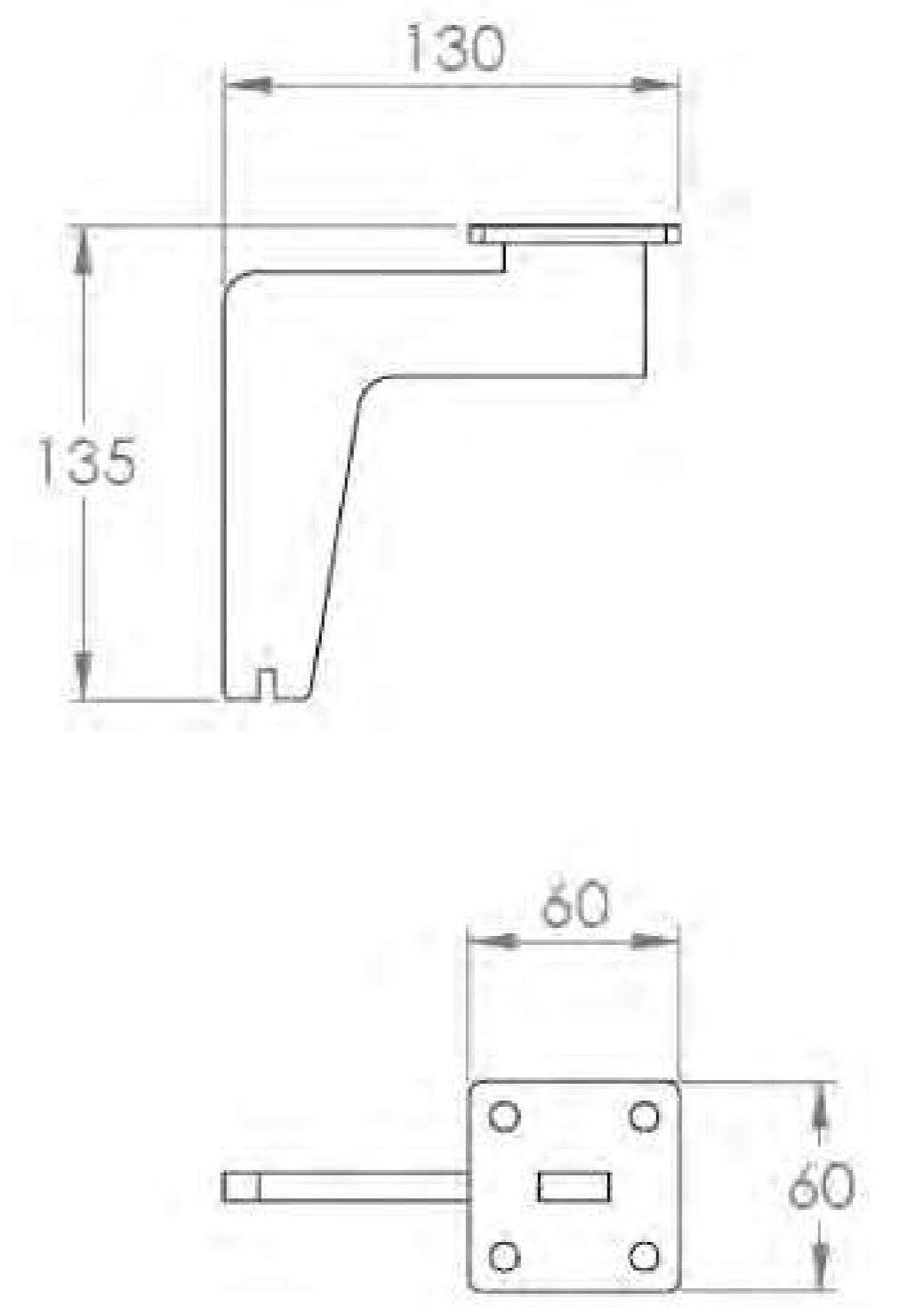

Color Chart

SMT-302

Specification Metal Leg

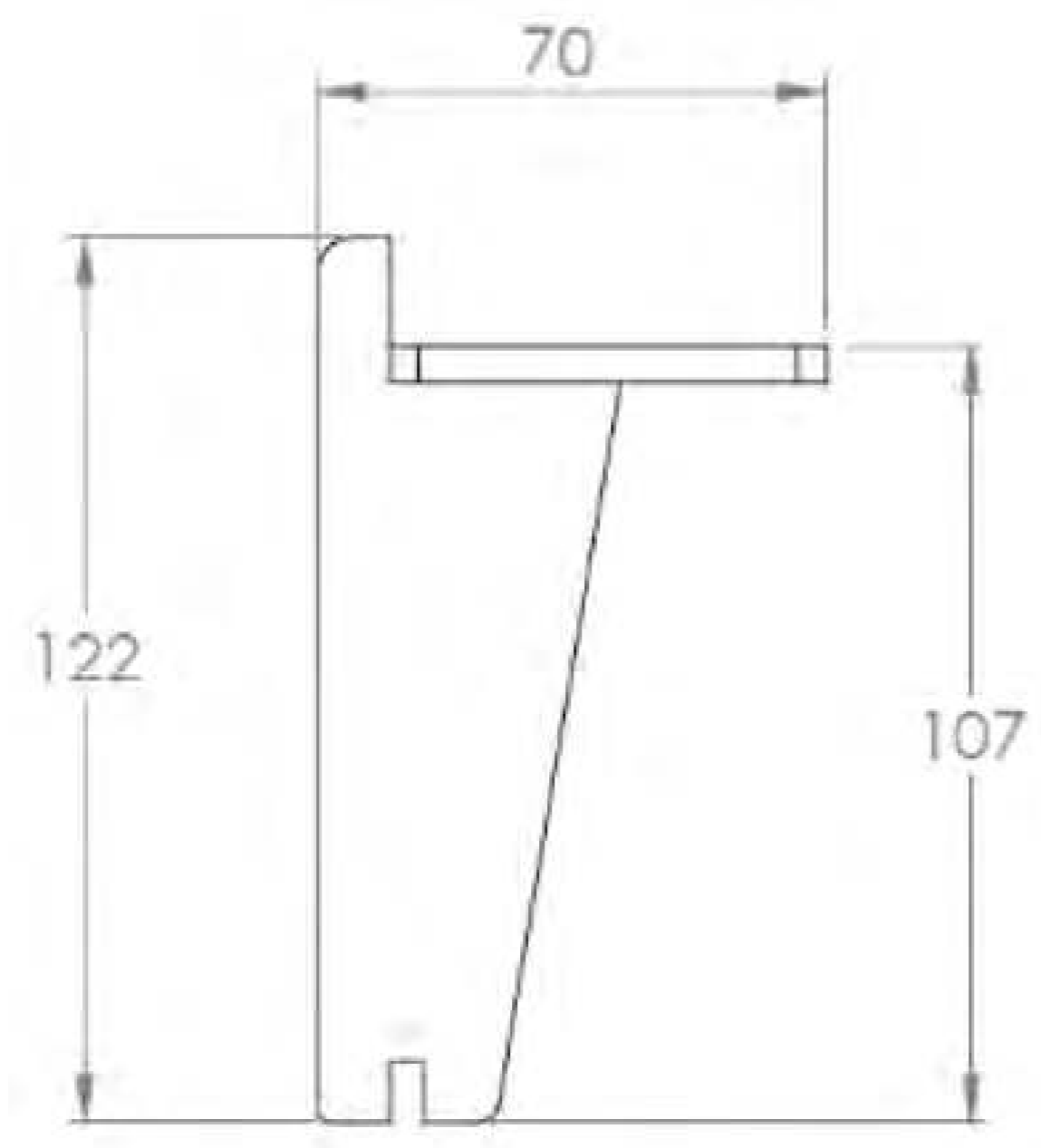

Color Chart

SMT-303

Specification Metal Leg

Color Chart

SMT-401

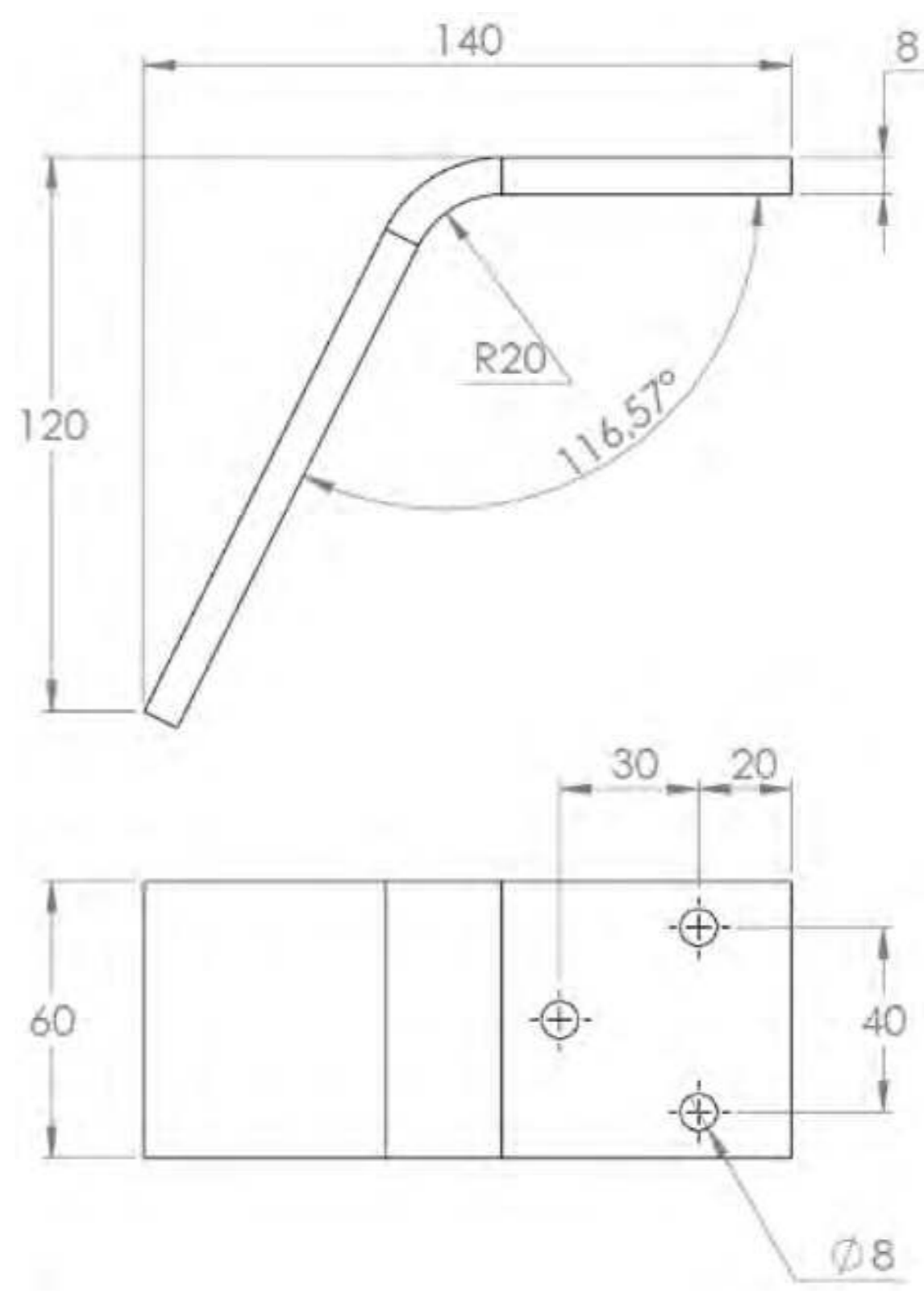
Specification Metal Leg

Color Chart

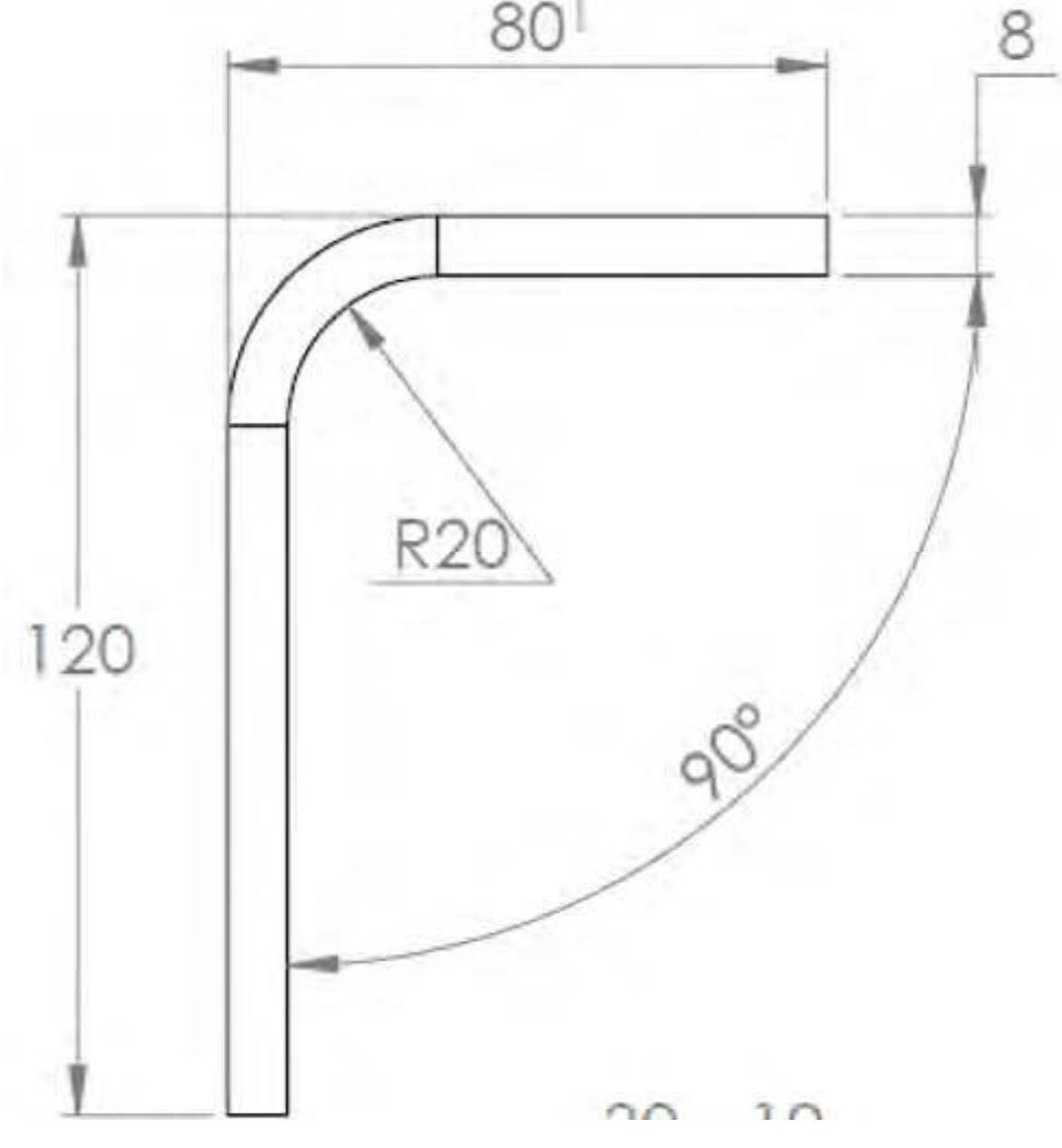

Furniture Legs

SMT-402

Specification Metal Leg

Color Chart

SMT-403

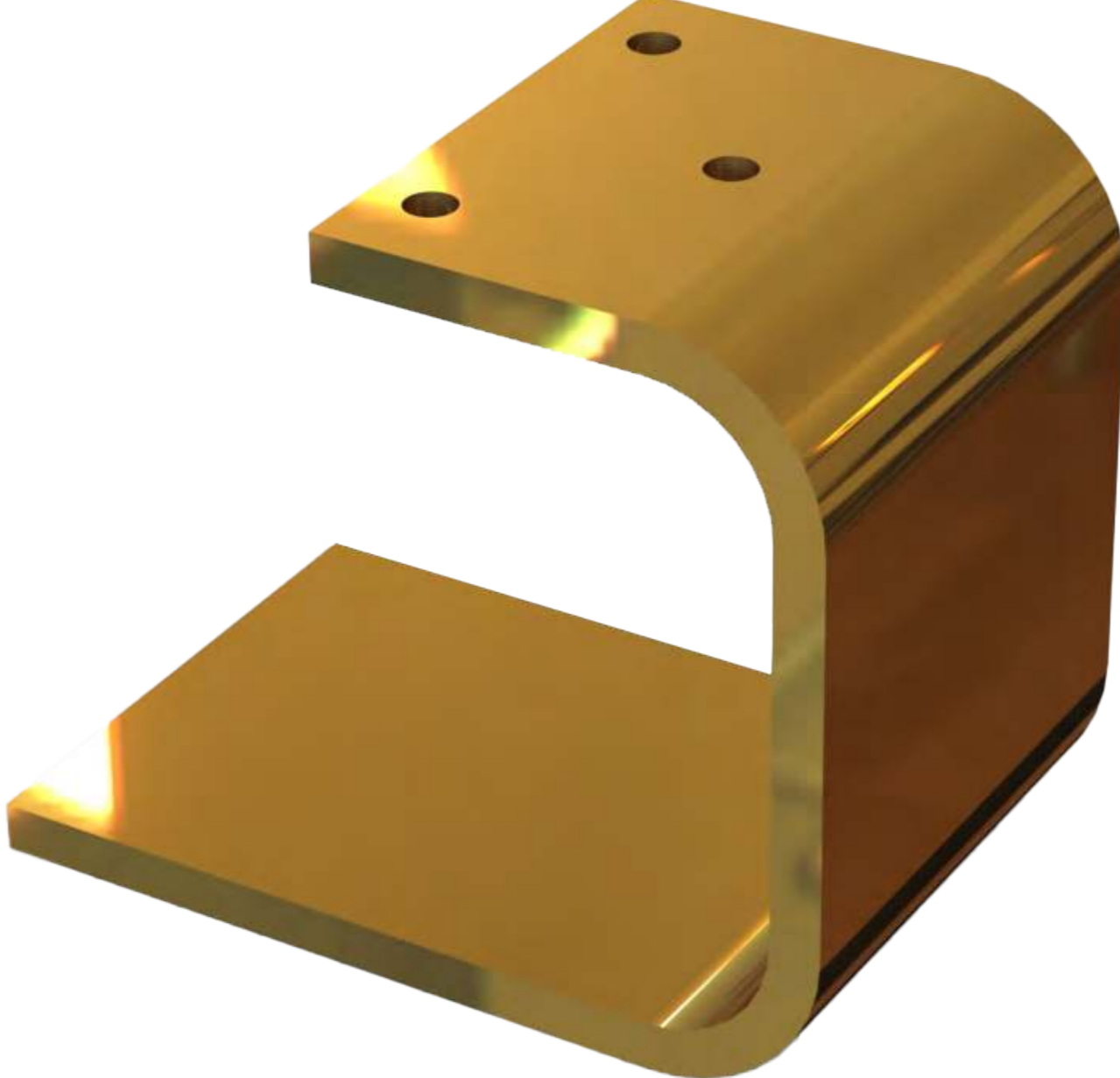
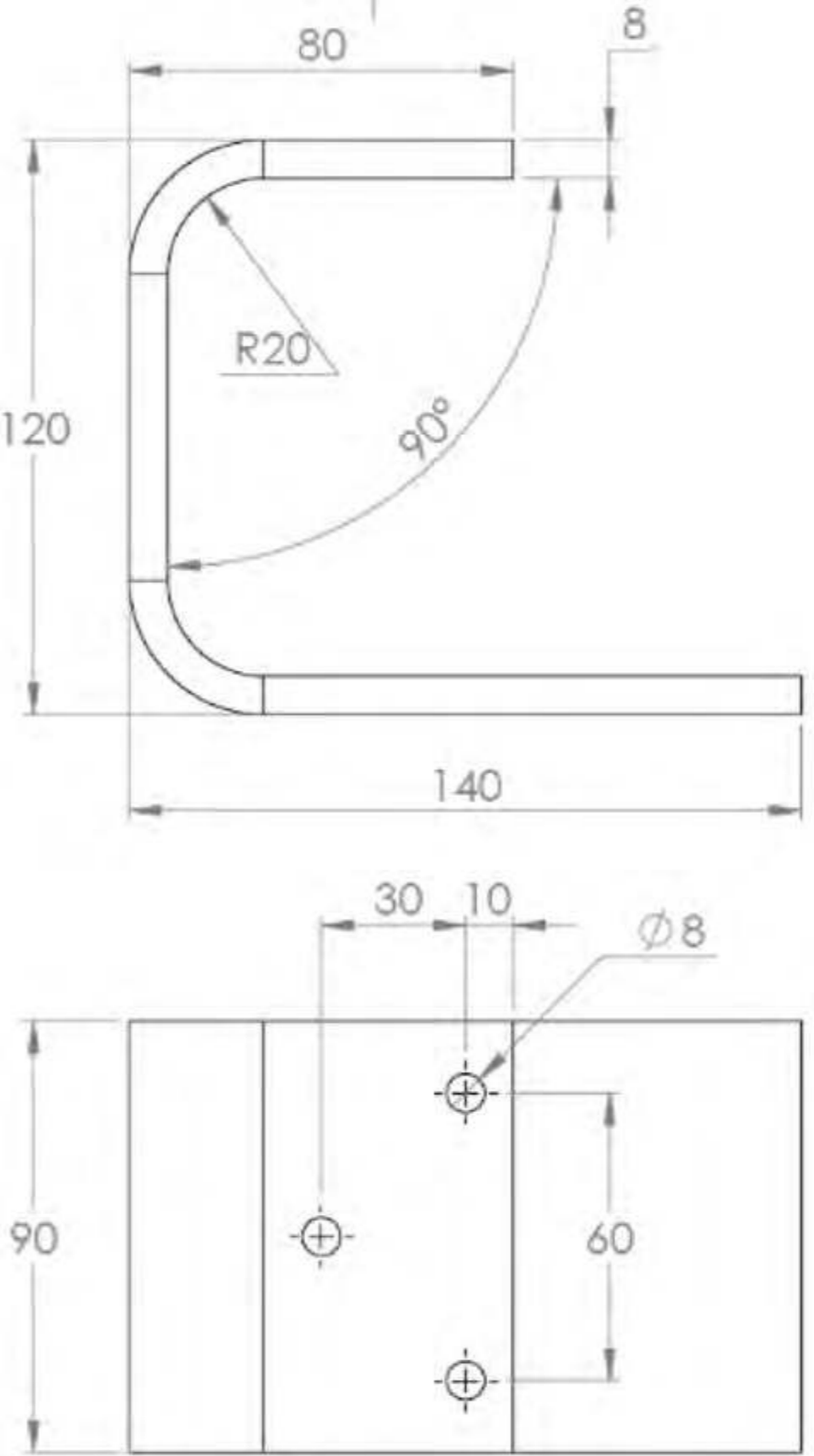
Specification Metal Leg

Color Chart

SMT-404

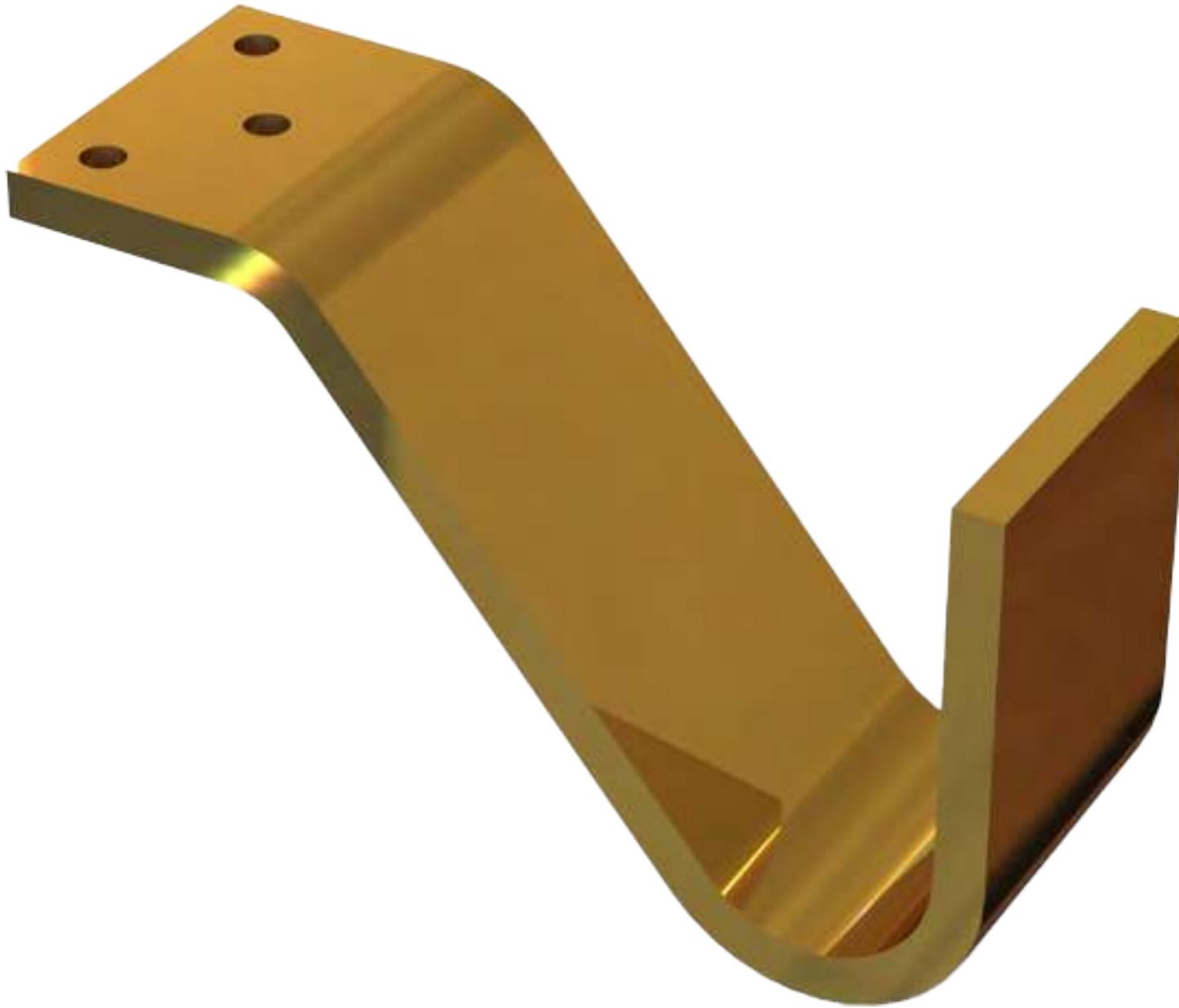
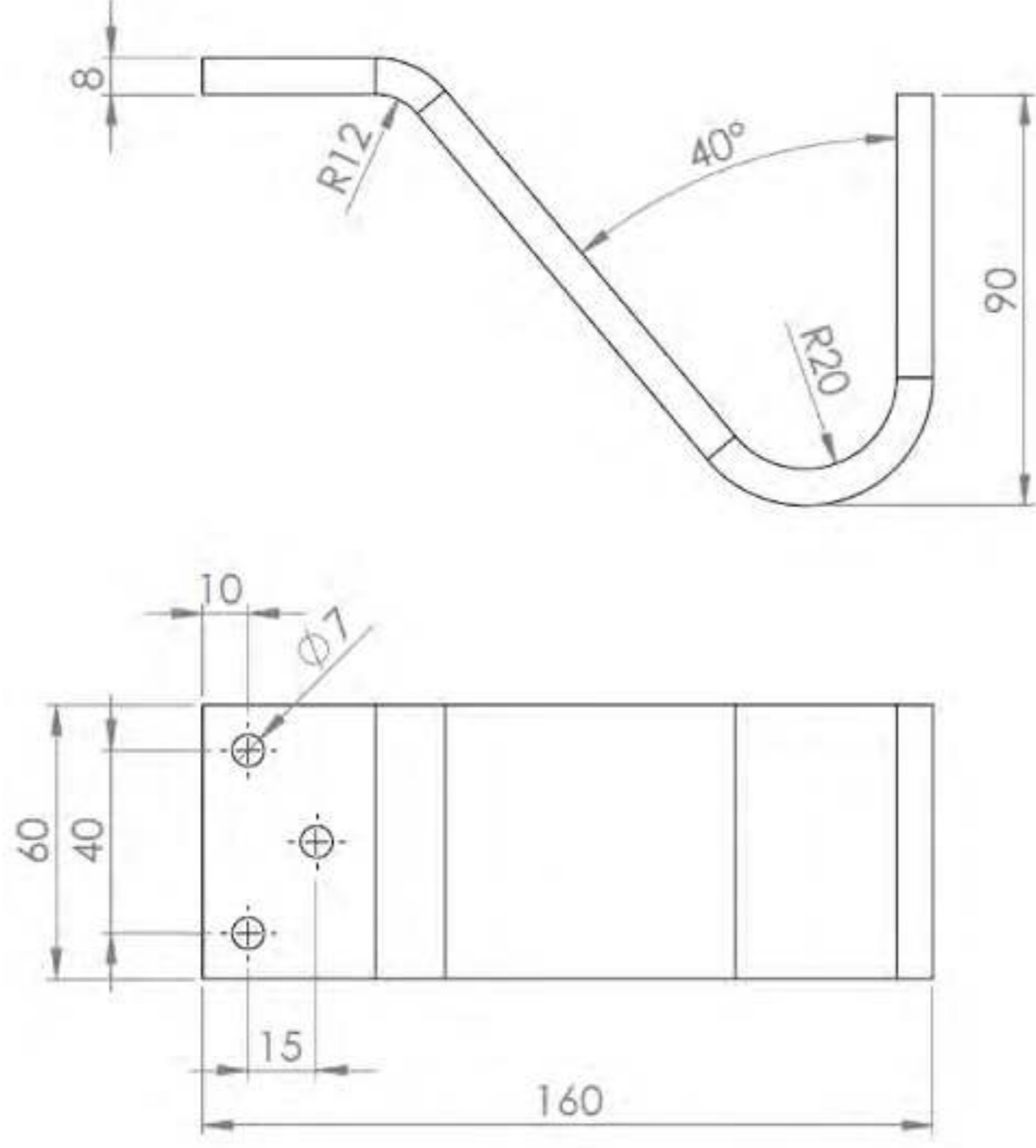
Specification Metal Leg

Color Chart

SMT-405

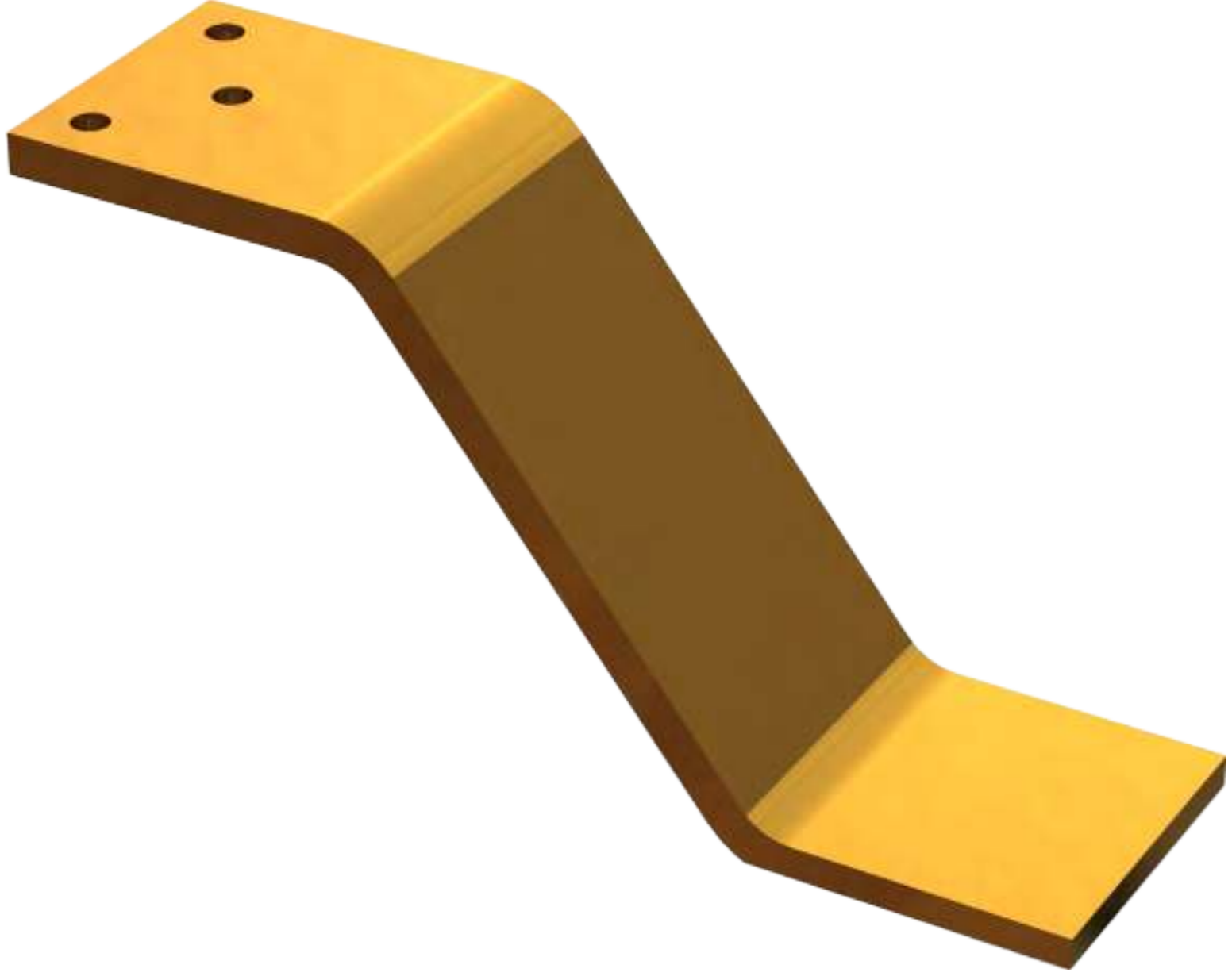
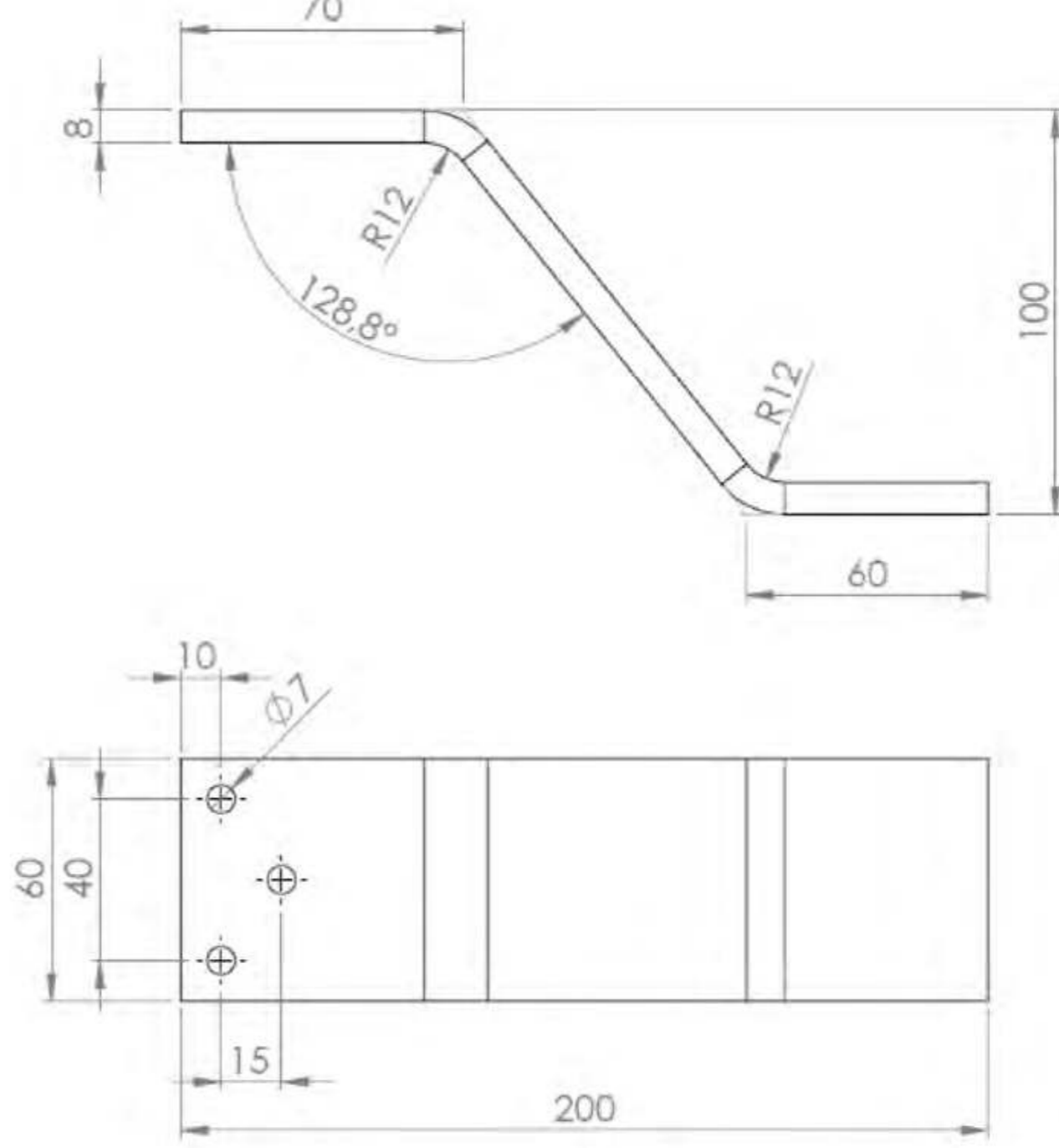
Specification Metal Leg

Color Chart

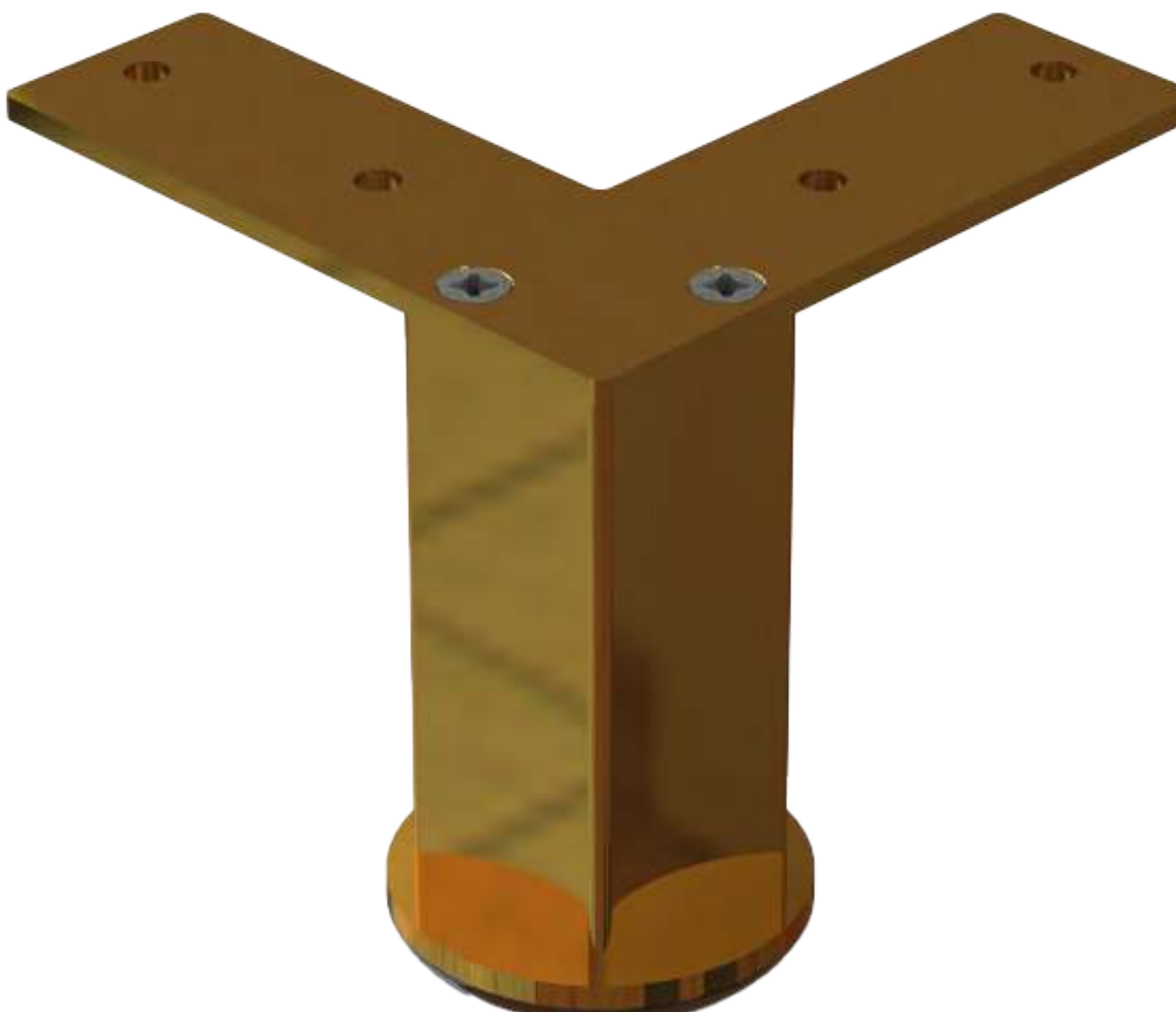
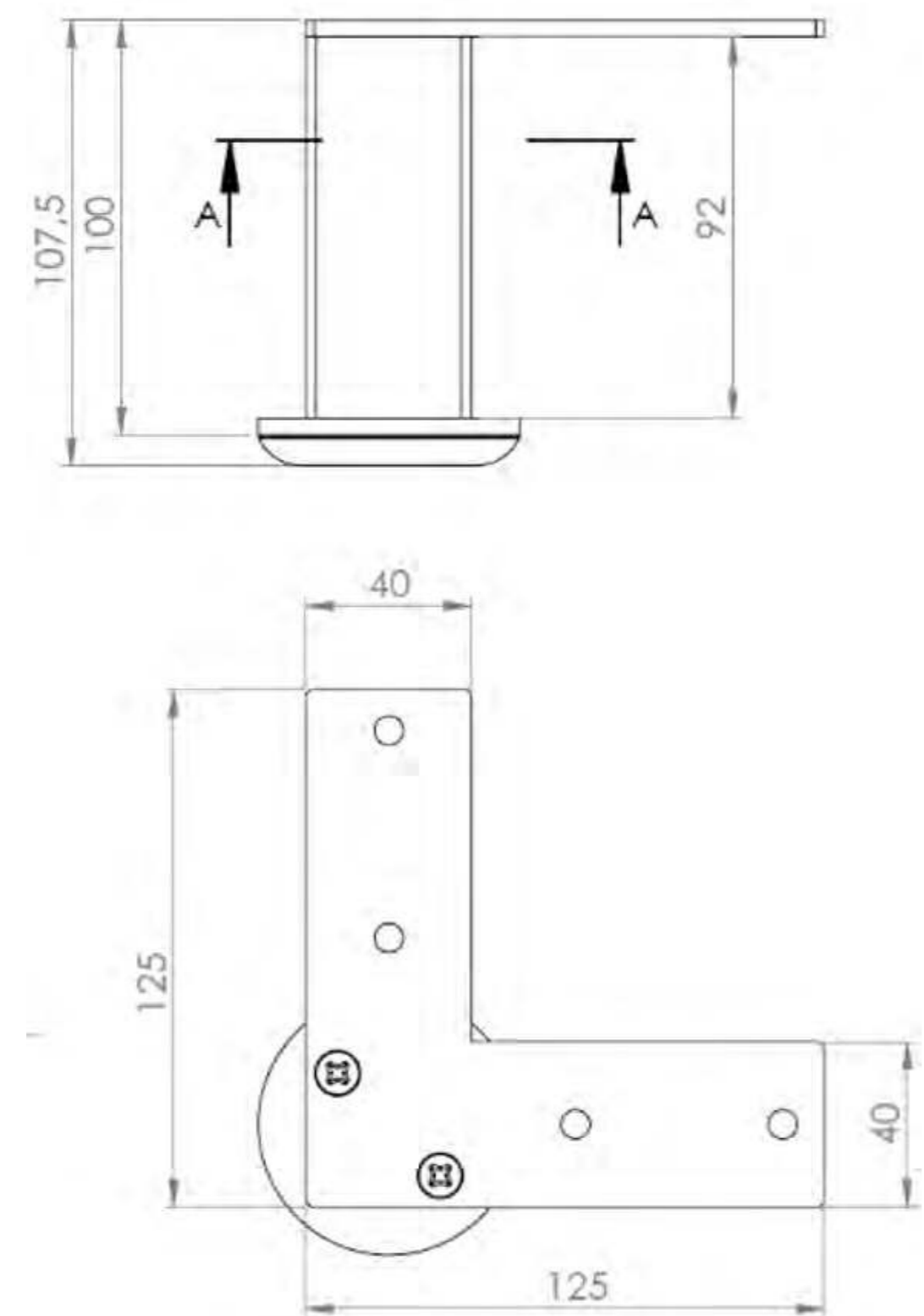

Furniture Legs

SMT-406

Specification Metal Leg

Color Chart





SMT-407

Specification Metal Leg

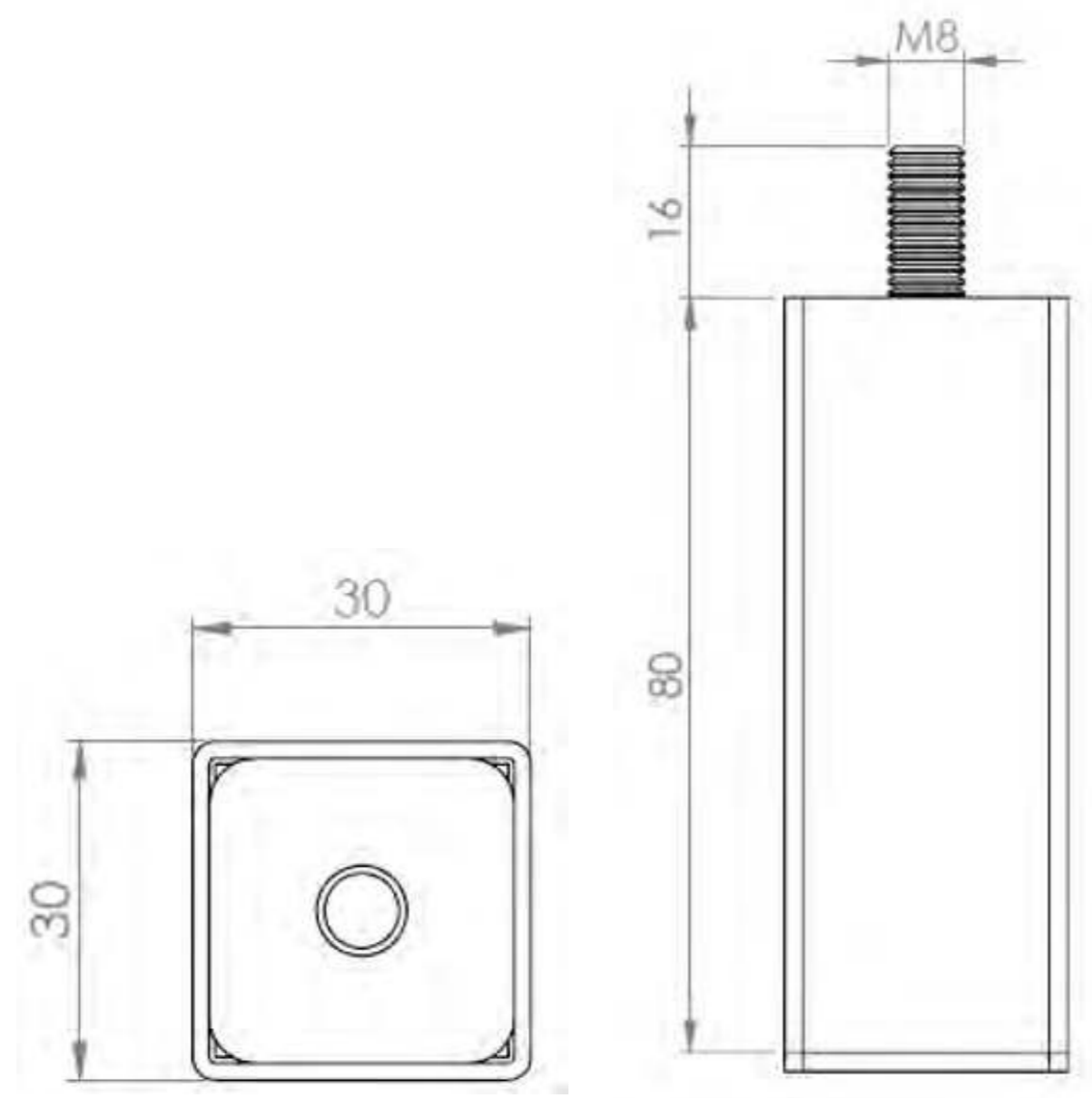

Color Chart

SMT-408

Specification Metal Leg

Color Chart

SMT-409

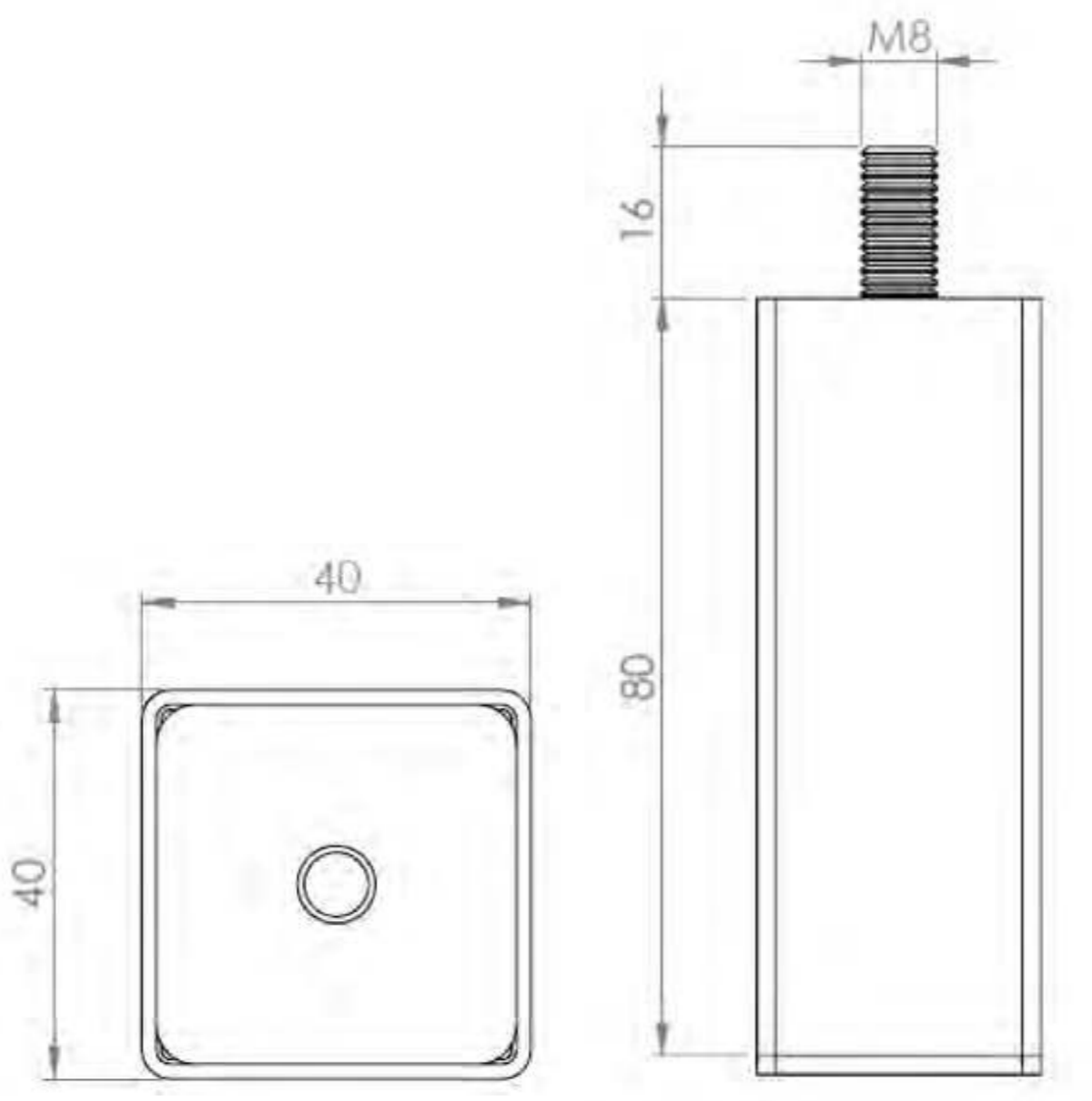
Specification Metal Leg

Color Chart



Furniture Legs

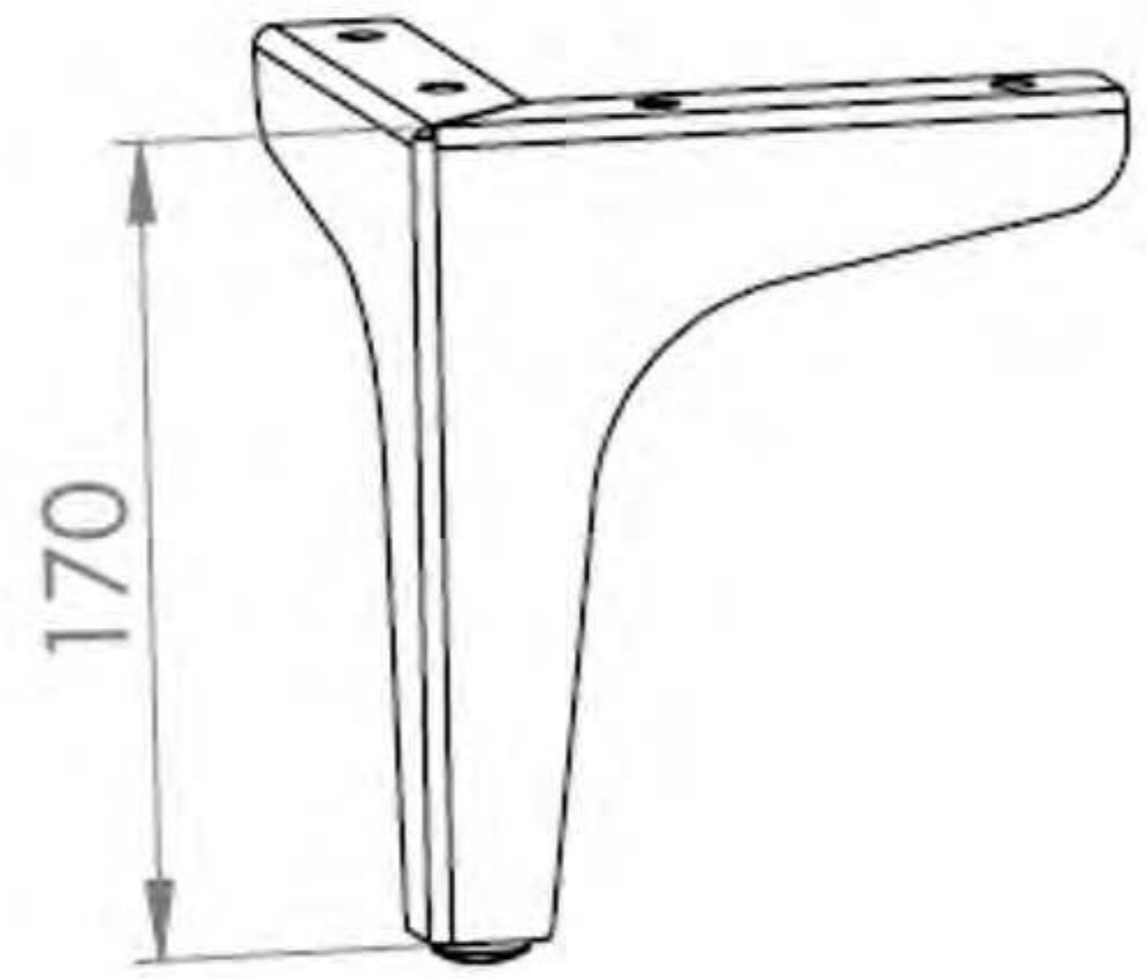

SMT-410

Specification Metal Leg

Color Chart

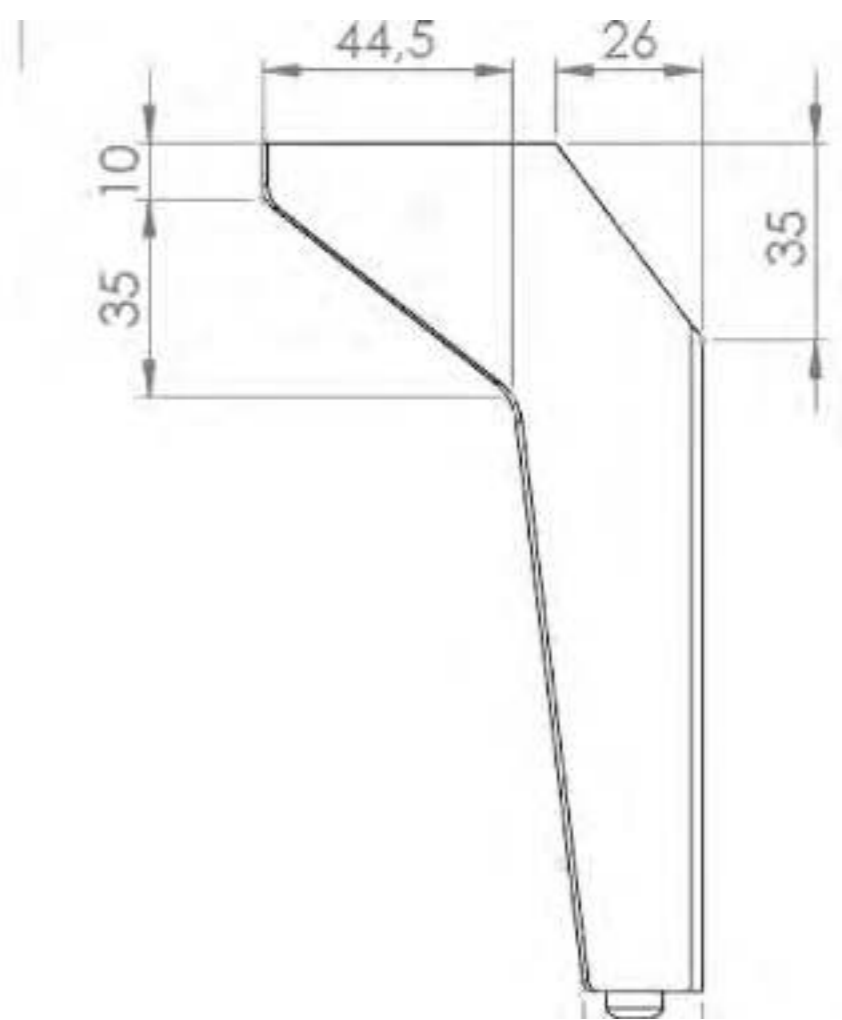
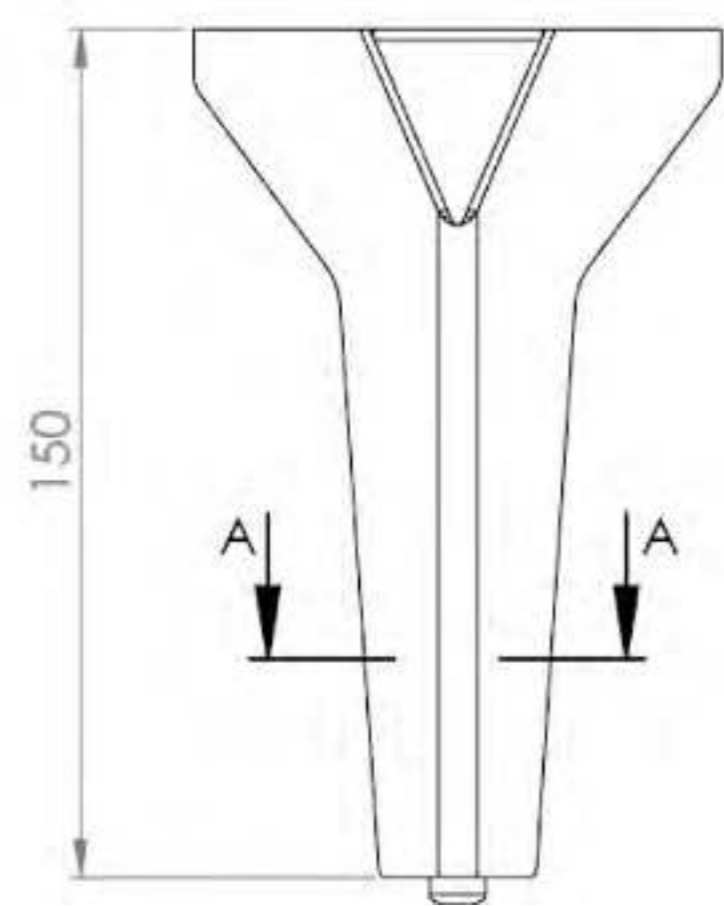

SMT-411

Specification Metal Leg

Color Chart



SMT-901

Specification Aluminum Leg

Color Chart



SMT-902

Specification Aluminum Leg

Color Chart



Furniture Legs



SMT-903

Specification Aluminum Leg

Color Chart



SMT-904

Specification Aluminum Leg

Color Chart



Chair Legs



Chair Leg

Specification Metal Leg



Chair Leg

Specification Metal Leg



Chair Leg

Specification Metal Leg



Chair Leg

Specification Metal Leg



Chair Legs



Chair Leg

Specification Metal Leg



Chair Leg

Specification Metal Leg



Chair Leg

Specification Metal Leg



Bar Stool and Chair Legs



Bar Stool Leg

Specification Metal Leg

Color Chart



Bar Stool Leg

Specification Metal Leg

Color Chart



Cinema and Conference Seats Metal Parts



Seat Leg

Specification Metal Leg



Seat Leg

Specification Metal Leg

Table Legs



Table Leg

Specification Metal Leg



Table Leg

Specification Metal Leg



Table Leg

Specification Metal Leg



Table Leg

Specification Metal Leg

Seat Frames

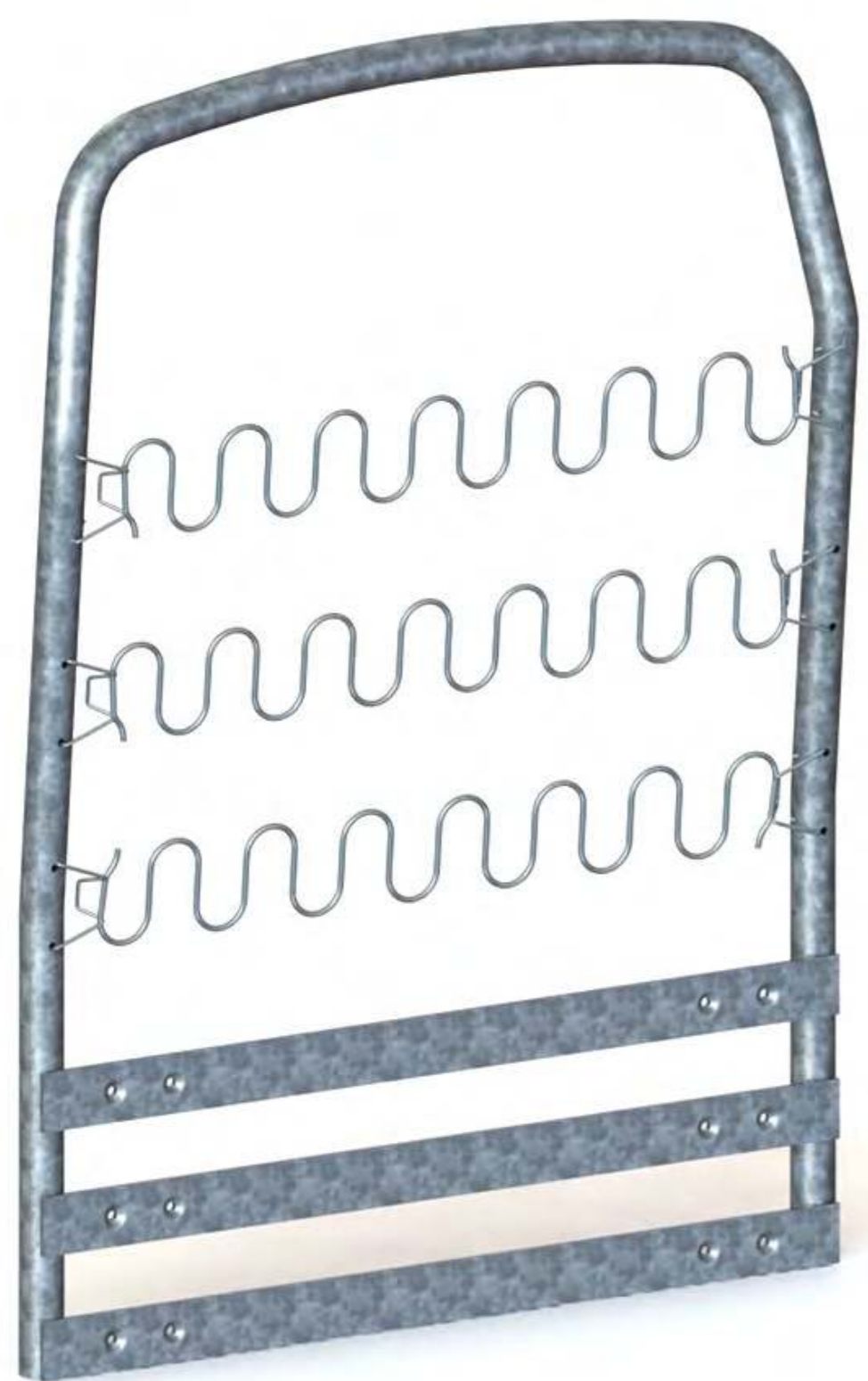

Seat Frame

Specification Metal Leg

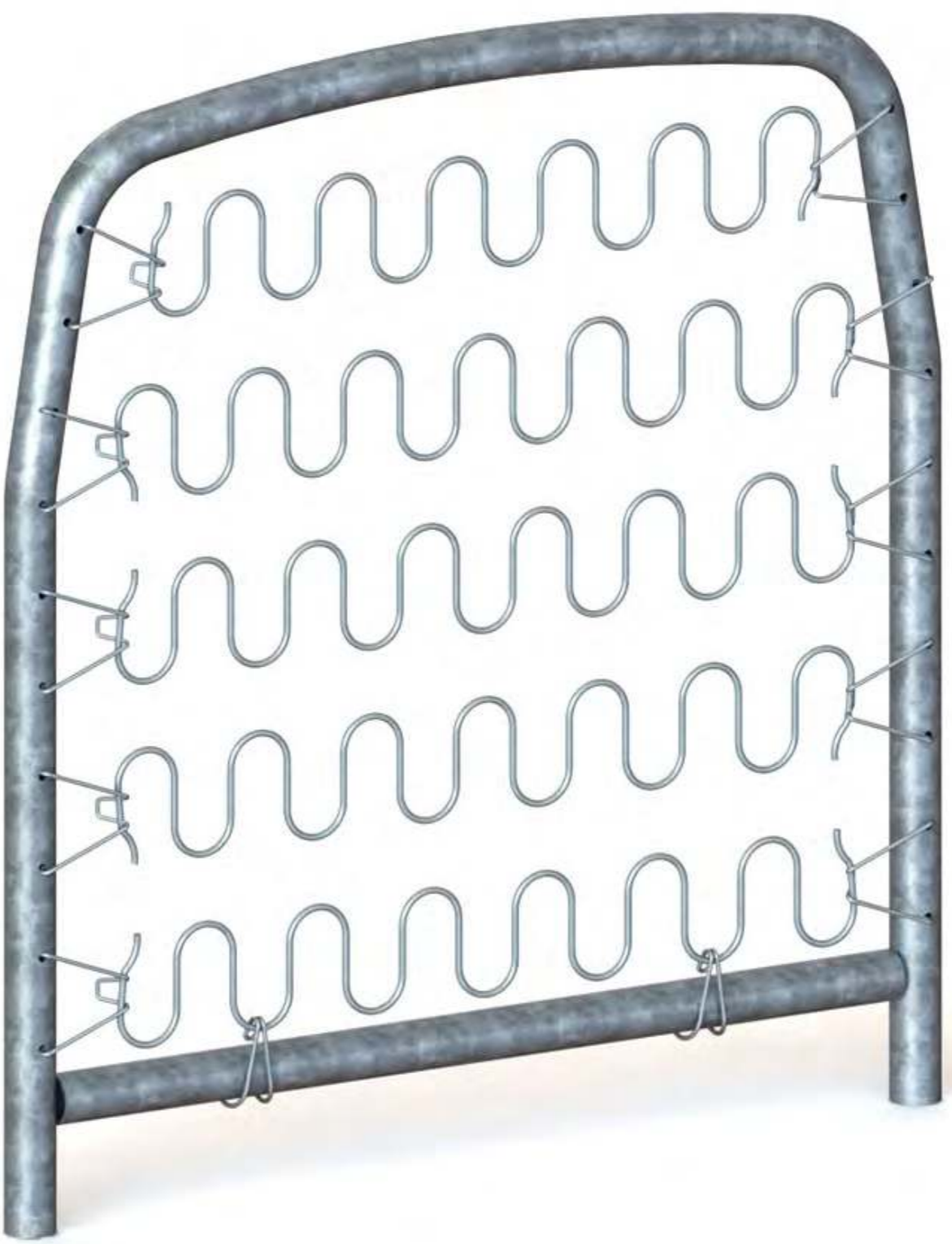

Seat Frame

Specification Metal Leg

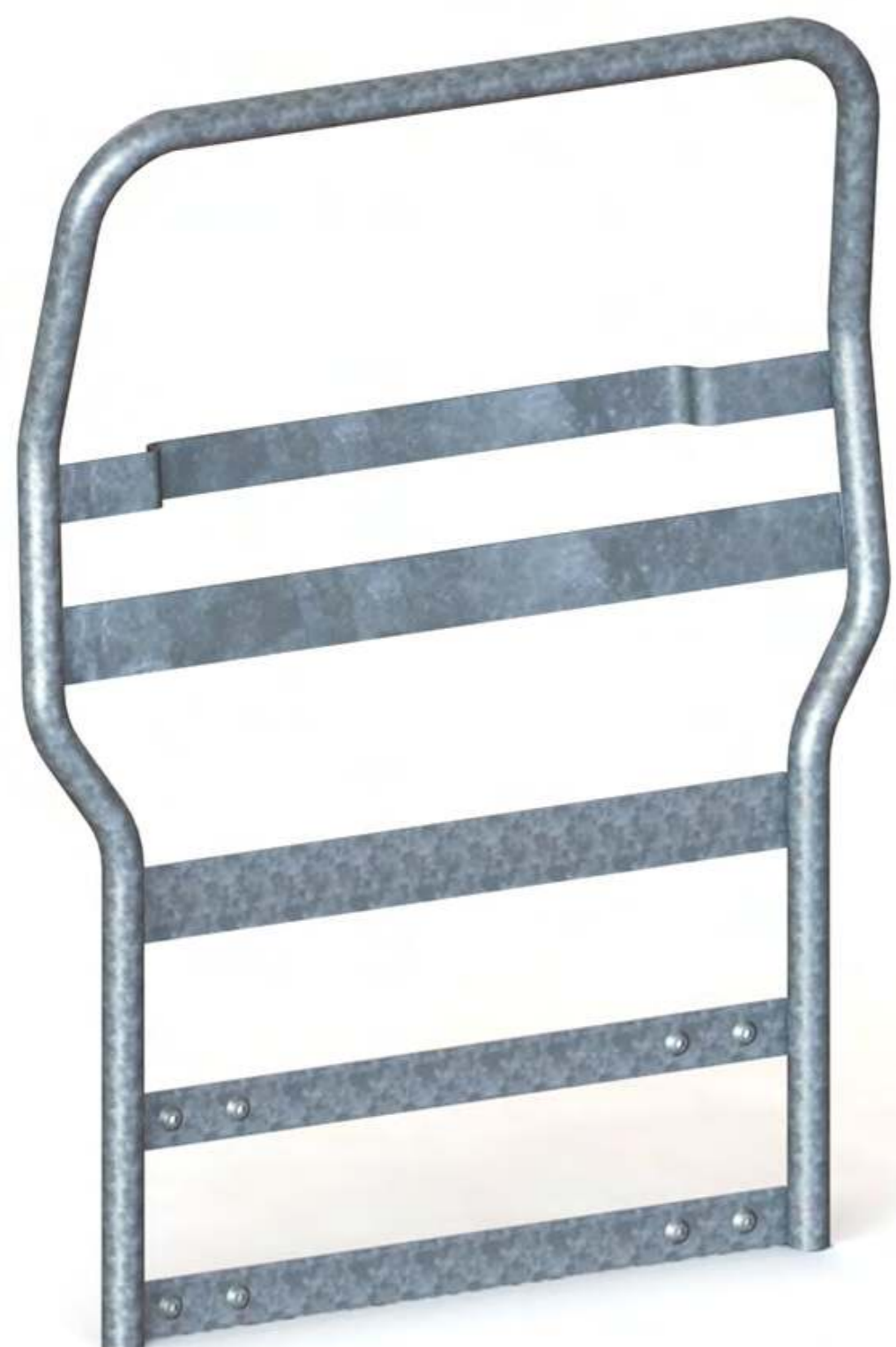

Seat Frame

Specification Metal Leg

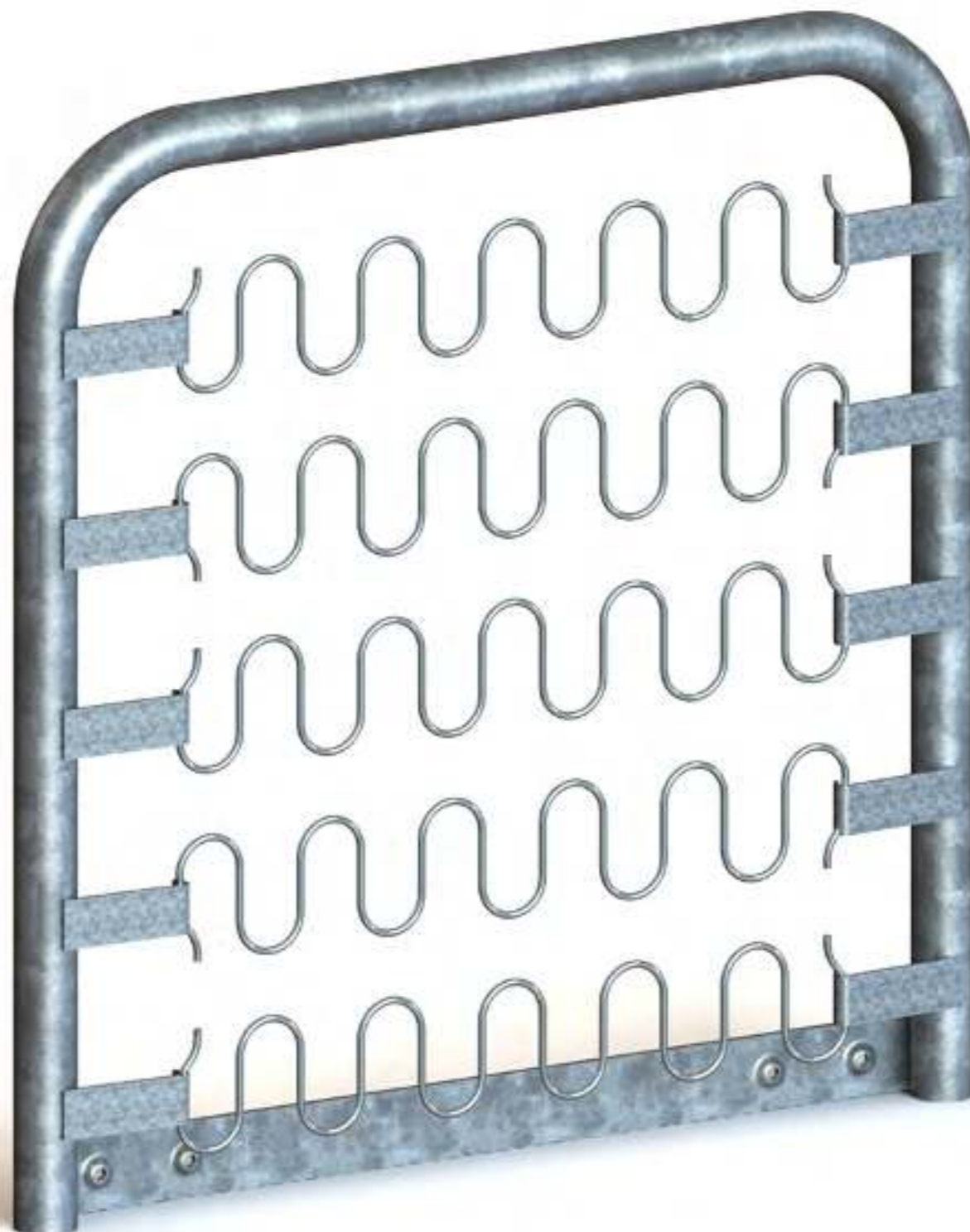

Seat Frame

Specification Metal Leg

Innovative Designs Sustainable Solutions

Samtaş Kalıp Yedek Parça Makina
Mob. Tas. Dek. İth. İhr. San. ve Tic. A.Ş.
İzmir Yolu 22. Km. Mümingençoğlu Cad.
No.2 Nilüfer, Bursa/Türkiye
+90 224 470 30 19

info@samtaskalip.com
www.samtaskalip.com

